

CARE AND MAINTENANCE

- Regular cleaning of the pump may be necessary depending upon the environment in which it is operated. Clean the pump when it is visibly soiled or when a drop in performance is detected.
- Before cleaning, always disconnect the pump from the power source.
- Remove all parts from the pump and clean in warm, soapy water.
- Disassemble the pump housing and remove the impeller housing to expose the impeller assembly. Remove the impeller assembly by gently pulling on the impeller blades. Use a soft cloth or brush to clean the impeller assembly and the inside of the impeller housing.

TROUBLESHOOTING

If the pump fails to operate:

- Check to make sure the power cord is plugged in and the pump is getting power.
- Check the pump outlet and any tubing, fountains, spitters etc. for kinks or obstructions.
- Remove the inlet screen and/or pump cover, and impeller housing to expose the impeller. Turn the impeller to ensure that it is not broken or jammed.

If the performance of the pump is not satisfactory or the pump does not flow evenly:

- Check to make sure the pump is completely submerged in water.
- Check to make sure the impeller and the housing are clean.
- Adjust flow control.

REPLACEMENT PARTS LIST

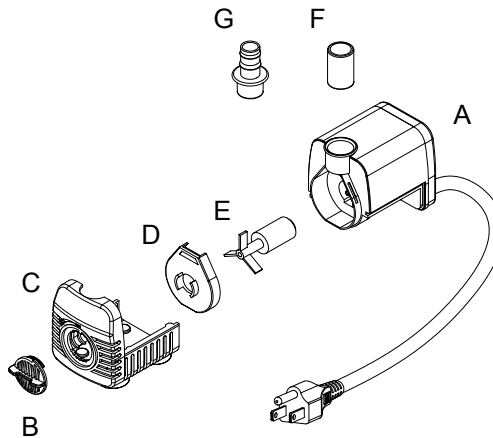

Part	Description
A	Pump
B	Flow control knob
C	Front cover
D	Impeller cover
E	Impeller assembly
F	Adapter for 1/2" tubing
G	Adapter for 1/4" tubing

For replacement parts, contact our customer service department at **909-424-0221**.
8 am – 4:30 pm PST, Monday through Friday.

Submersible Fountain Pump 130 Gallons per Hour

model

ALP

PACKAGE CONTENTS	
Part	ALP
Description	Pump
Quantity	1

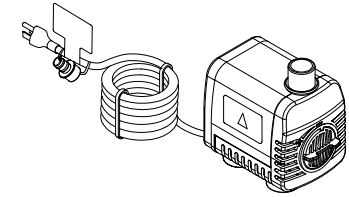

Questions, problems, missing parts?

Before returning to your retailer, contact our customer service department at **909 424-0221**
8 am – 4:30 pm, PST, Monday - Friday, or
e-mail us at info@alsgardenart.com

AL'S GARDEN ART

Manufacturers of cast stone fountains and statuary since 1949, family owned and operated with more than half a century of skill and passion for creating top quality cast stone art.

QUALITY SET IN STONE



P.O. Box 111 • Colton, CA 92324

www.alsgardenart.com

⚠ WARNINGS AND CAUTIONS

WARNING

- Risk of electrical shock. This pump is supplied with a grounding conductor and grounding-type attachment plug. To reduce the risk of electric shock, be certain that it is connected only to a properly grounded, grounding-type receptacle (GFCI).
- Do not exceed the voltage shown on the pump.
- Always disconnect pump from the power source before beginning any maintenance or work on the pump.
- Inspect cord for damage before installation and/or maintenance. Replace the entire pump assembly if damage is found.
- Do not remove the grounding pin from the power cord plug.
- Risk of electrical shock – This pump has not been investigated for use in swimming pool or marine areas.

CAUTION

- This pump has been evaluated for use with water only.
- Use a proper power source as indicated on the pump label.
- Keep the cord away from high temperatures or other heat sources.
- Avoid using the pump when water temperatures fall below 41° F.
- Do not use the pump in water exceeding 86° F.
- Do not pump heated liquids.
- Do not let the pump run dry. Pump must be completely submerged for proper operation and cooling.

⚠ WARNINGS AND CAUTIONS (Cont'd)

- Operate in freshwater only. Avoid heavily chlorinated water and water with high pH levels.
- Do not lift the pump by its power cord.

PREPARATION

Before beginning assembly or operation of product, make sure all parts are present. Compare parts with package contents list on the cover and diagram on the reverse side of this document. If any part is missing or damaged, do not attempt to assemble, install or operate the product. Contact customer service for replacement parts.

- Estimated Assembly Time: 5 minutes
- No tools required for assembly.

WARRANTY

This warranty is offered to you as an extra benefit and does not affect your rights as a consumer in any way. This unit has been checked for compliance to performance requirements at the time of manufacture and are made in accordance with the requirements set forth in UL778 to insure safe operations over the life of the product. This pump is warranted against manufactured defect for one (1) year from the date of purchase. Proof of purchase is required for all warranty claims. The warranty is not valid if defects are caused by tampering, negligence, misuse or not observing safety warnings. No responsibility is assumed for indirect damage that may result from the use of this appliance.

ASSEMBLY INSTRUCTIONS

1. Connect tubing to the outlet of the pump.
Fig 1

NOTE: Tubing is NOT INCLUDED

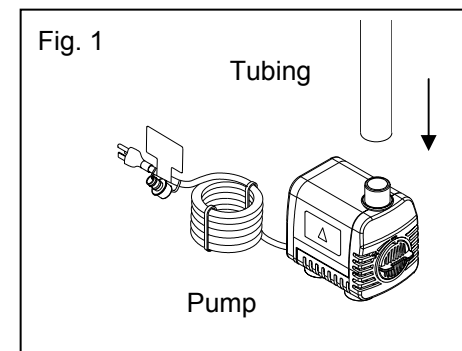

2. Place the pump into the water and connect to a proper power source.
Fig. 2

